



TRANSLATION OF THE ORIGINAL

# USER MANUAL



## V-MAX mini

EINFACH LEICHT SCHIEBEN

CE

2023-06 (1.1)

EN

# AAT service concept

Customer service at its best



With our professional service concept we at AAT prove once again our high claim of quality and offer our clients an all-inclusive package.

We are at your service!

- Spare parts
- Repair processing
- Technical information
- Product seminars
- Showroom & exhibition devices
- Re-use
- Complaints
- Rental devices



## Service and repairs

Phone +49.(0) 74 31.12 95-550  
Phone +49.(0) 74 31.12 95-552  
Fax +49.(0) 74 31.12 95-540  
E-mail [service@aat-online.de](mailto:service@aat-online.de)

## Assembly team

Phone +49.(0) 74 31.12 95-555  
Phone +49.(0) 74 31.12 95-557  
Fax +49.(0) 74 31.12 95-558  
E-mail [anbau@aat-online.de](mailto:anbau@aat-online.de)

## New devices

Phone +49.(0) 74 31.12 95-110  
Phone +49.(0) 74 31.12 95-125  
Fax +49.(0) 74 31.12 95-35  
E-mail [vertrieb@aat-online.de](mailto:vertrieb@aat-online.de)

## Head office

Phone +49.(0) 74 31.12 95-0  
E-mail [info@aat-online.de](mailto:info@aat-online.de)  
Web [www.aat-online.de](http://www.aat-online.de)



AAT Alber Antriebstechnik GmbH  
Ehestetter Weg 11 · 72458 Albstadt · Germany  
Phone: +49.(0) 74 31.12 95-0  
Fax: +49.(0) 74 31.12 95-35  
[info@aat-online.de](mailto:info@aat-online.de) · [www.aat-online.de](http://www.aat-online.de)



The product is state of the art and complies with the associated technical safety requirements. Nevertheless, a low level of residual risks cannot be ruled out. Please observe the safety instructions to this end.

All serious incidents occurring in relation to the device must be reported to the manufacturer and to the competent authority of the Member State where the user and/or occupant is established.



#### WARNING

Failure to observe this user manual, in particular the safety instructions can lead to defects in the **V-MAX mini** and endanger the operator and the occupant, as well as affect it in its proper function! There is an increased risk of injury! In the event of an infringement, claims for warranty and liability are excluded!

Persons with visual and reading impairments or mental disabilities should print out the user manual available on the website in enlarged letters or have this manual read to them, if necessary. You will also find all safety-relevant changes that have been made to the user manual on our homepage. All versions with details of the production period of the product are obtainable at:

**[www.aat-online.de/gb](http://www.aat-online.de/gb) > Downloads > Rehabilitation > User manuals > V-MAX mini**

# Table of Contents

<b>1</b>	<b>Symbols and safety instructions</b>	<b>.5</b>
<b>2</b>	<b>Explanation of the symbols on the packaging</b>	<b>.6</b>
<b>3</b>	<b>Explanation of the symbols on the device and the type plate.</b>	<b>.7</b>
<b>4</b>	<b>Product description</b>	<b>.8</b>
4.1	Device overview	.8
4.2	Overview of type plate incl. serial number	.9
4.3	Intended purpose	.9
4.4	Intended patient population	.9
4.5	Medical requirements and indication	.9
4.6	Contraindications and restrictions	10
4.7	User group	10
4.8	Technical data	11
4.9	Dimensional drawing.	12
4.10	Scope of delivery	13
4.11	Accessories	13
<b>5</b>	<b>Assembly</b>	<b>14</b>
5.1	Wheelchair bracket	14
5.2	Battery holder	14
5.3	Drive unit.	15
5.4	Battery	16
5.5	Operating unit	16
5.6	Anti-tip supports	17
<b>6</b>	<b>Starting up</b>	<b>18</b>
6.1	Switching on the device	19
6.2	Riding with the <b>V-MAX mini</b>	20
6.3	Overcoming obstacles / folding up.	22
6.4	Deactivating the drive	23
6.5	Immobiliser / protection against unauthorised use	23
<b>7</b>	<b>Removal</b>	<b>24</b>
<b>8</b>	<b>Transportation</b>	<b>26</b>
<b>9</b>	<b>Care and maintenance</b>	<b>26</b>
9.1	Battery and charger	27
9.2	Cleaning and disinfection	32
9.3	Disposal	33
9.4	Long-term storage	34
9.5	Technical safety testing	34
9.6	Reuse (change in operator)	35
9.7	Corrective action/recall	35
<b>10</b>	<b>Status information</b>	<b>36</b>
10.1	Fault conditions	36
10.2	Troubleshooting	36
<b>11</b>	<b>Warranty and liability.</b>	<b>37</b>



# 1 Symbols and safety instructions



## **DANGER - Immediately imminent danger**

If not avoided, this will result in death or severe bodily injuries!



## **WARNING - Possibly imminent danger**

If not avoided, this may result in death or severe bodily injuries!



## **CAUTION - Possibly imminent danger or harmful situation**

If not avoided, this may result in minor bodily injuries or damage to property!



## **NOTE - Information by the manufacturer**

### General safety instructions



#### **NOTE**

Read the user manual prior to start-up and observe the warning notices and safety instructions.

In the event of reading disabilities, cover training content in more depth verbally.

The user manual must be kept in a safe place after reading through it.

Some materials have a certain fuel grade and are therefore made of special flame-retardant material. Nevertheless, the **V-MAX mini** must be kept away from sources of ignition, as it does not consist exclusively of flame-retardant materials.

The **V-MAX mini** may interfere with highly sensitive electromagnetic fields of other electronic devices (e.g. anti-theft devices).

Stability tests were performed under laboratory conditions. The **V-MAX mini** may behave differently under real conditions compared to laboratory tests.

Training may only be carried out by the manufacturer, the AAT field staff or the qualified specialist shop.

We generally recommend the use of a wheelchair with drum brakes, as the **V-MAX mini** does not include an own brake function.



#### **CAUTION**

External heat sources may cause the surface temperature to rise (e.g. sunlight)!

Do not touch the affected surfaces in this case to avoid burns!



## DANGER

The **V-MAX mini** must not be operated in the case of severe visual impairment and/or blindness!

Do not exceed the total permissible weight and the maximum person weight, as this may lead to defects or overload the **V-MAX mini**.





Avoid driving in heavy rain, ice, snow and on unsurfaced ground (sand, mud, loose crushed rock) to prevent slipping!

Do not use on escalators or travellers to avoid injuries caused by a crash or the falling out of the occupant and the occurrence of damage to property!

The operability of the **V-MAX mini** may be influenced by electromagnetic fields (e.g. by mobile phones, electric generators, or high-voltage sources)!

Do not store near medical devices, for example with a life support function, and diagnostic devices, as these may malfunction!

## 2 Explanation of the symbols on the packaging

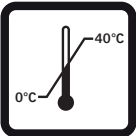
Symbol	Explanation
	<b>Handle with care</b> The packaging including the product must be handled with special care.
	<b>Protect from moisture</b> Protect the packaging including the product from overly high air humidity. Cover during storage. If necessary, cover thoroughly with tarpaulins.
	<b>Caution fragile</b> Handle the packaging including the product carefully and never allow it to fall.
	<b>This way up</b> The packaging must be stored and transported in such a way that the arrows point upwards at all times. Any failure to comply with this rule, such as rolling or tilting the package, must be avoided.
	<b>Temperature limit 0 to 40 °C</b> Please do not store packaging incl. product and battery below/above the specified temperature limits.

### 3 Explanation of the symbols on the device and the type plate

Symbol	Explanation
	<b>CE marking</b> Position: Type plate The product complies with the relevant provisions of the EC Regulation EC 2017/745 (MDR)
	<b>Date of manufacture</b> Position: Type plate Indicates the year the medical device was manufactured.
	<b>Manufacturer</b> Position: Type plate Shows the manufacturer of the medical device (AAT Alber Antriebstechnik GmbH)
	<b>SN</b> Position: Type plate Serial number of the product e.g. P1204XXXXXX
	<b>Medical Device</b> Position: Type plate
	<b>Barcode</b> Position: Type plate <b>Contains the AAT serial number</b>
	<b>Technical safety test badge</b> <b>(refer to chapter Technical safety test)</b> Position: Underside of drive unit Informs about the due date of the next technical safety test
	<b>Double hook symbol</b> Position: Carrying handle Informs that when folding the device, the carrying handle must be connected to the double hook.
	<b>Observe the user manual!</b> Position: On the right next to the type plate The user manual must be observed! ( <a href="http://www.aat-online.de">www.aat-online.de</a> ) Refers to the need for the user to review the user manual and important safety-related information.

## 4 Product description

### 4.1 Device overview



#### Manufacturer information:

For a simplified assignment of the individual components, the numbers listed here are cited in full for the first time in the following chapters.

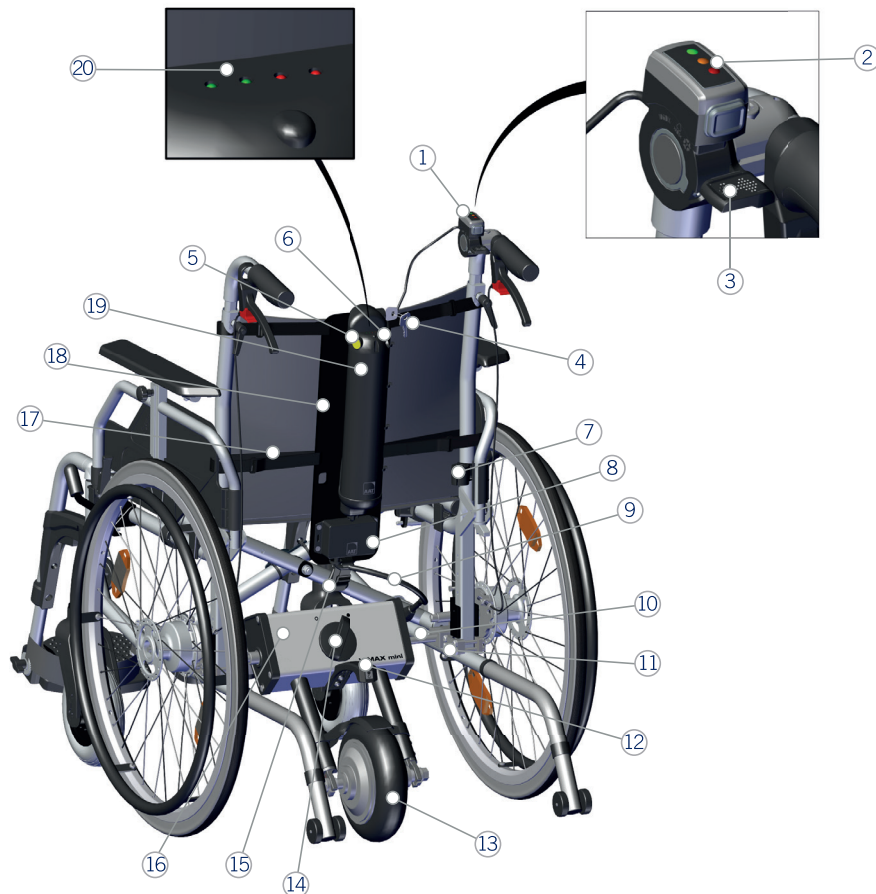

- |   |                                   |
|---|-----------------------------------|
| ① Operating unit                        | ⑫ Carrying handle                 |
| ② Battery charge level indicator        | ⑬ Drive wheel                     |
| ③ Thumb throttle                        | ⑭ Release switch                  |
| ④ Key for battery locking device        | ⑮ Double hook (for attaching)     |
| ⑤ Charging socket                       | ⑯ Drive unit                      |
| ⑥ ON/OFF switch / emergency stop switch | ⑰ Velcro tapes for battery holder |
| ⑦ Holder for power cable                | ⑱ Battery holder                  |
| ⑧ Electronics box                       | ⑲ Lithium-ion battery             |
| ⑨ Power cable                           | ⑳ Battery charge level indicator  |
| ⑩ Guide shafts                          |                                   |
| ⑪ Wheelchair bracket                    |                                   |

Type plate incl. serial number  
on the underside of the drive unit

## 4.2 Overview of type plate incl. serial number

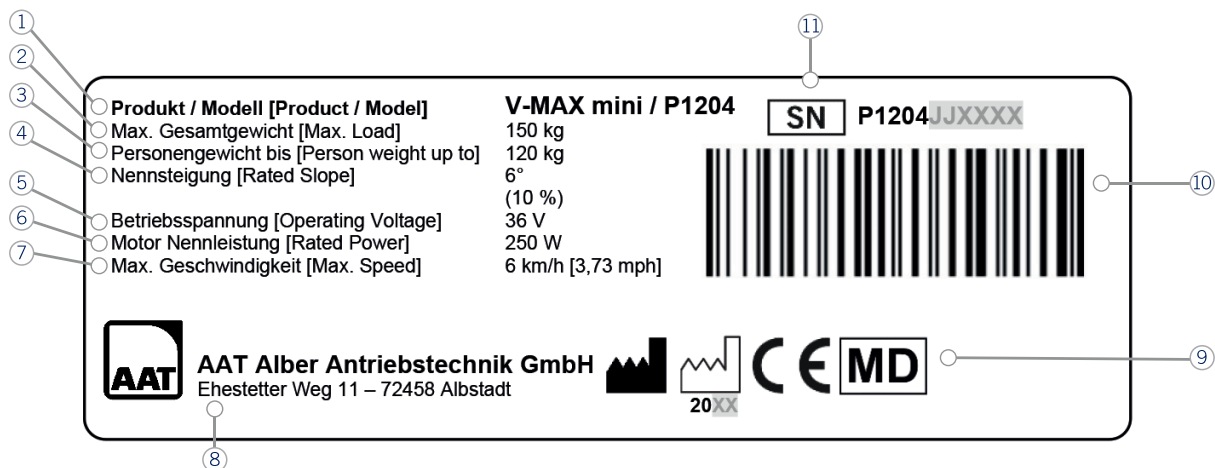

- |                        |                                      |
|------------------------|--------------------------------------|
| ① Product / Model      | ⑦ Max. speed                         |
| ② Max. total weight    | ⑧ Manufacturer address               |
| ③ Person weight up to* | ⑨ Symbols (refer to chapter 3)       |
| ④ Rated slope          | ⑩ Barcode (refer to chapter 3)       |
| ⑤ Operating voltage    | ⑪ Serial number (refer to chapter 3) |
| ⑥ Rated power of motor |                                      |

## 4.3 Intended purpose

The power assist devices are intended for their use on manual wheelchairs and to assist the accompanying person while pushing the wheelchair. The accompanying person of a single person in the wheelchair is assisted both on level surfaces and slopes. The power assist devices have been designed for indoor and outdoor use.

## 4.4 Intended patient population

The intended patient population includes all people with their own manual wheelchair. Users of the V-MAX mini may have a permissible person weight of 120 kg (total weight incl. device and wheelchair 150 kg).

## 4.5 Medical requirements and indication

There are no medical requirements.

A power assist supports the accompanying person while pushing the wheelchair. The use of the power assist is intended for patients who are not able to move by themselves and accompanying persons who do not have sufficient physical endurance and strength to move the patient over a longer period of time / over longer distances.

## 4.6 Contraindications and restrictions

The power assist devices must not be used if:

- the operator has obtained no training/instruction for the product
- the operator is not physically and mentally able to operate the device safely
- in the case of severe visual impairment and/or blindness
- more than one person shall be transported simultaneously
- the operator does not have adequate eyesight
- escalators or travelators shall be overcome
- medical devices with e.g. a life support function, and diagnostic devices are in the proximity
- it is not used according to the intended use
- objects shall be transported

## 4.7 User group

The power assist devices are intended for the use by:

- health care professionals
- laymen.

Users are trained in the use of the device by means of a training course.

## 4.8 Technical data



**WARNING** - Do not exceed the total permissible weight and the maximum person weight, as this may lead to defects or overloading the **V-MAX mini!**



**NOTE** - Observe the technical data.

Technology	V-MAX mini
Battery pack	Lithium-ion
Drive dimensions	Refer to chapter "Dimensional drawing"
Own weight	Drive: 6.0 kg Battery holder incl. interface: 0.8 kg Total weight without battery: 6.8 kg Battery: 1.5 kg Charger: 0.37 kg
Total permissible weight	150 kg (wheelchair + person + <b>V-MAX mini</b> ) <sup>1,4</sup>
Maximum person weight	120 kg <sup>(4)</sup>
Limit values during construction	From seat width 36 cm to seat width 48 cm Smaller or larger seat widths and camber on request
Possible wheel sizes in inches	20" to 24"
Speed forward	Up to 6 km/h
Range per battery charge for a total weight of 150 kg	Up to 15 km <sup>2</sup>
Rated slope for max. person weight	10 % (6°) with 120 kg <sup>3,4</sup>
Batteries	Nominal capacity 36 V / 6.4 Ah (230, 4 Wh) - Minimum capacity 36 V / 6.0 Ah (216 Wh)
Direct current motor	36 V / 250 W
Noise information	The A-weighted sound pressure level is typically below 54 dB(A)
Switching/actuating forces	Pressing the thumb throttle: 2.5 N - 4 N
Static stability downhill	Observe the information in the wheelchair manufacturer's user manual.
Static stability sideways	Observe the information in the wheelchair manufacturer's user manual.
Maximum surmountable obstacle height	Observe the information in the wheelchair manufacturer's instructions for use and the chapter "Overcoming obstacles".
Storing/operating temperature: Device	-40 °C to +65 °C / -25 °C to +50 °C
Storing/operating temperature: Battery pack	Briefly: -20 °C to +40 °C <sup>5</sup> / -20 °C to +65 °C (ISO 7176-9)
	Recommendation: -20 °C to +40 °C <sup>5</sup> / -20 °C to +35 °C
Charging temperature: Battery pack	0 °C to +40 °C
Vibration information	The weighted RMS value of acceleration, to which the upper body is subjected, is typically below 2.5 m/s <sup>2</sup> .
Degrees of protection, IP class	IPX4
Adhesive label with serial number	Back of device

(1) Observe the maximum load according to the wheelchair manufacturer's information.

(2) According to ISO 7176-4, the distance range depends, among other factors, on the weight of the transported person, the ground, the terrain profile, the ambient temperature, etc.

(3) The rated slope also depends on the surface, terrain profile, ambient temperature etc.

(4) The person weight on the type plate and in the technical data were calculated using an assumed wheelchair weight of 20 kg.

(5) At temperatures below 0 °C the performance of the battery pack will decrease; therefore we recommend a storage temperature of at least 0 °C.



## 4.9 Dimensional drawing

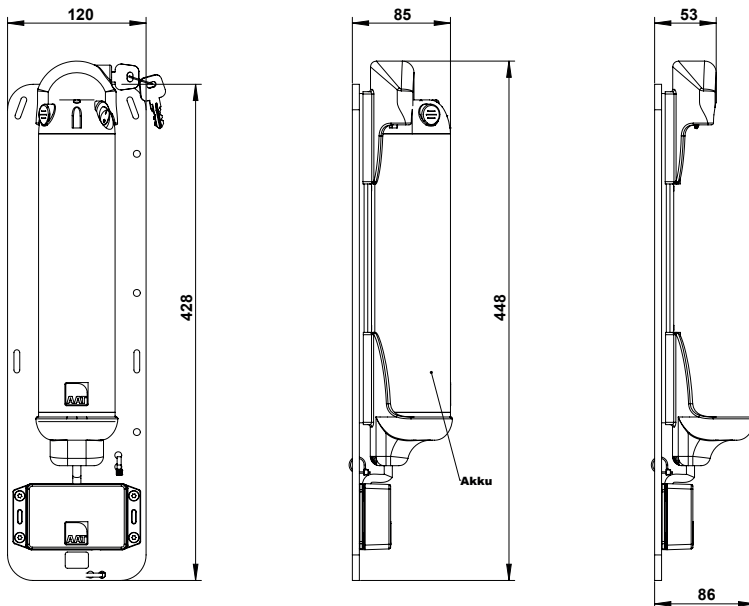
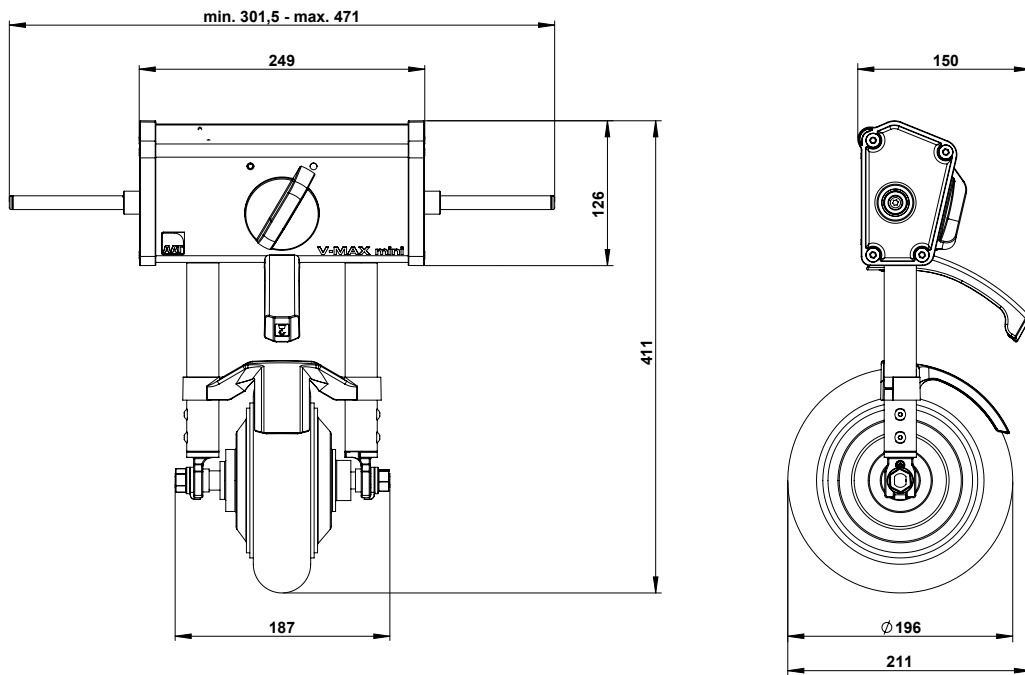

## 4.10 Scope of delivery



- |   |  |
|---|--|
| ① Drive unit <b>V-MAX mini</b>  | ⑤ Battery holder incl. Velcro tapes, electronics box and power cable |
| ② Operating unit  | ⑥ Key for battery locking device                                     |
| ③ Mount for operating unit (for wheelchairs without or with drum brake) | ⑦ Charger  |
| ④ Battery (lithium-ion)   | ⑧ Holder for power cable   |

## 4.11 Accessories

**i** NOTE - Only use AAT Alber Antriebstechnik GmbH accessories.

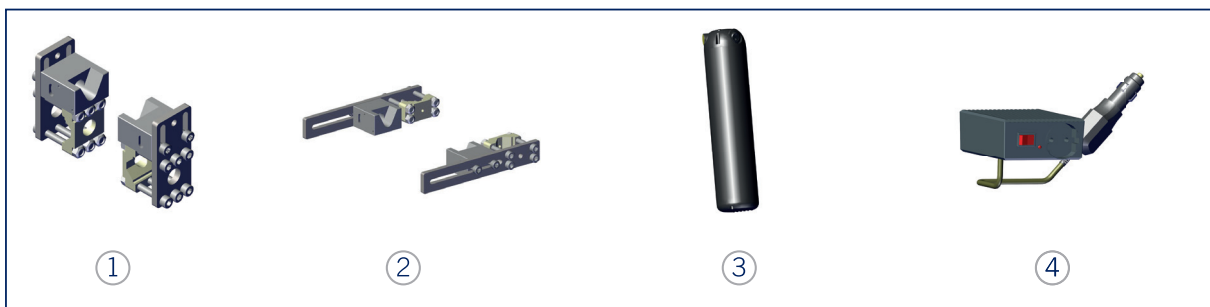

- |                                   |  |
|-----------------------------------|--|
| ① Wheelchair bracket (vertical)   | ④ Motor vehicle voltage converter 12 V / 230 V                                 |
| ② Wheelchair bracket (horizontal) | ⑤ Lighting kit according to StVO (German road traffic regulations) (no figure) |
| ③ Additional battery              |  |

## 5 Assembly

### 5.1 Wheelchair bracket



**Information by the manufacturer for the end user:** Fitting the bracket to the wheelchair is carried out by the authorised specialist dealer, the AAT field service or the manufacturer. Please contact one of these named contacts if you have any questions.

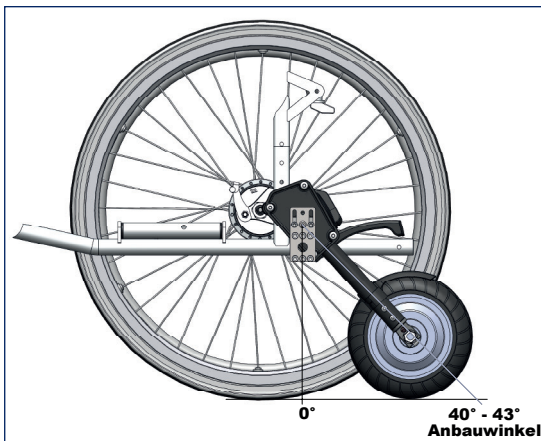

Sample illustration.

#### **Information for specialised dealers:**

When fitting the bracket, please observe the respective fitting instructions for the different wheelchair models.

You can obtain the fitting instructions from AAT or download them from our homepage:

[www.aat-online.de/gb](http://www.aat-online.de/gb)

> Agents area > List of brackets

### 5.2 Battery holder



**CAUTION** - Tighten the Velcro tapes well to avoid the battery holder from becoming detached.



The battery holder is equipped with four Velcro tapes.



Fix the Velcro tape to the upper and lower wheelchair frame.



Repeat on the other side. Tighten the Velcro tapes and fix any protruding tape in the retaining clip.

## 5.3 Drive unit



**DANGER-** The drive unit must be fully inserted in the bracket, as otherwise it may move unexpectedly and the drive guide shafts cannot be extended correctly!



**CAUTION -** Plug-in contacts must be dry!



### **Manufacturer's information:**

The width of the guide shafts has been adjusted especially for your wheelchair. If you have any questions or need to make any changes, please contact your authorised specialised dealer, the AAT field team or the manufacturer.

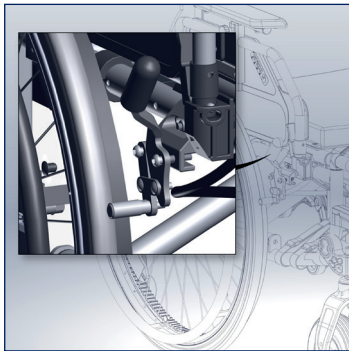

Activate the parking brakes to prevent the wheelchair from rolling away.

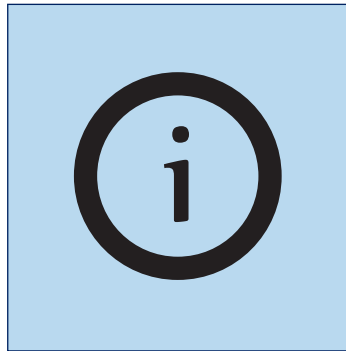

### **Manufacturer's recommendation:**

Only release the parking brakes after chapter "Assembly" has been complied with completely.

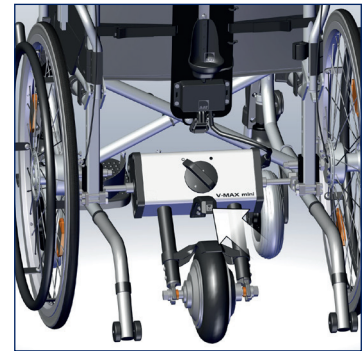

Insert the drive unit completely into the wheelchair bracket. Hold the drive by the carrying handle.

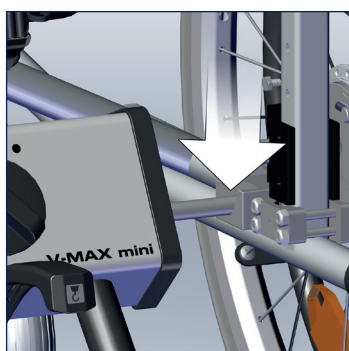

Make sure that both guide shafts are inserted evenly.



Turn the release switch completely to the right.  
» Will be locked.

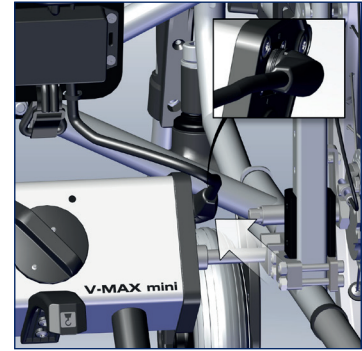

Plug the power cable into the drive unit.  
» Plug-in contact is made magnetically!

## 5.4 Battery



WARNING - Never short-circuit or connect the poles of the battery to avoid electric shocks!



WARNING - Never use the battery empty or defective, as failure of the battery on upward/downward slopes will cause the device incl. wheelchair to freewheel and suddenly require much more force for handling.



CAUTION - Plug-in contacts must be dry!

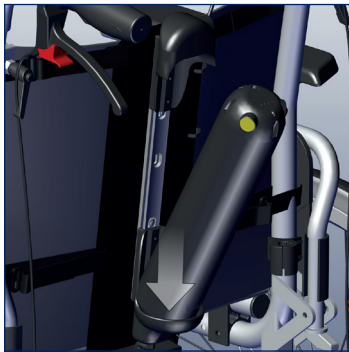

Insert the battery into the lower part of the battery holder.

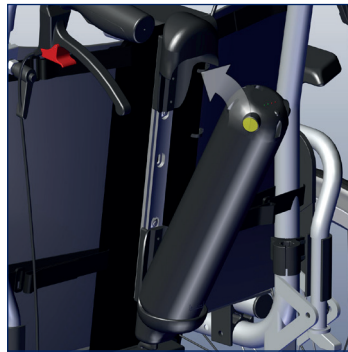

Click the battery into the upper part of the holder.

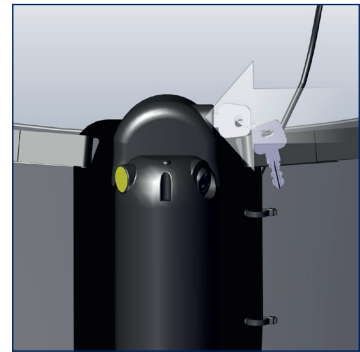

Insert the key for the battery locking device and turn it 180°.

» The battery is locked.

## 5.5 Operating unit



WARNING - The locking clamp must be tightened firmly, otherwise the operating unit can move abruptly!

### For wheelchairs with drum brake

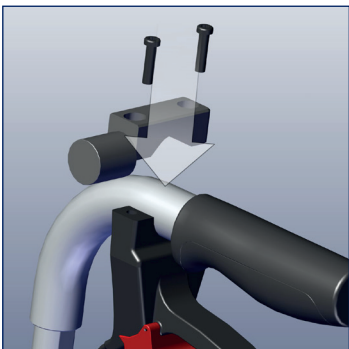

Fix the mount for the operating unit (one clamp) to the handbrake of the wheelchair and tighten it with the appropriate screws.

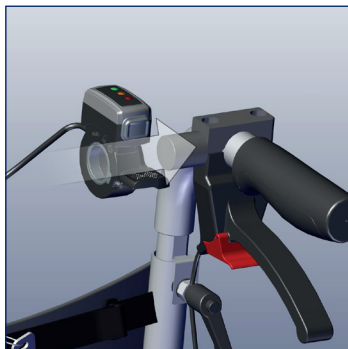

Plug the operating unit onto the round tube, set the appropriate angle and tighten the grub screw. Make sure it is tight.

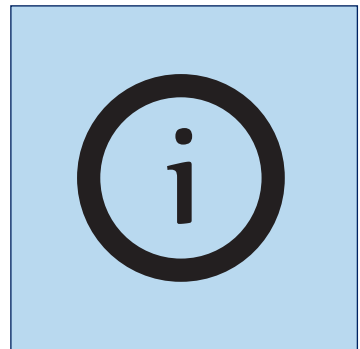

The pre-setting is carried out by specialised dealers or AAT.

### For wheelchairs without drum brake

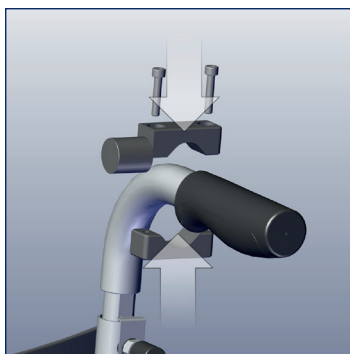

Fix the mount for the operating unit (two clamps) to the handle tube and tighten it with the appropriate screws.

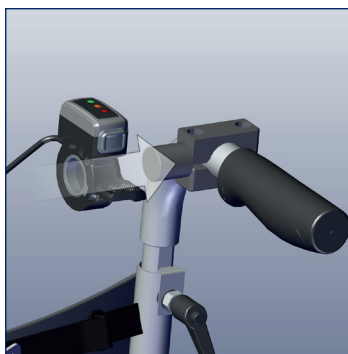

Plug the operating unit onto the round tube, set the appropriate angle and tighten the grub screw. Make sure it is tight.

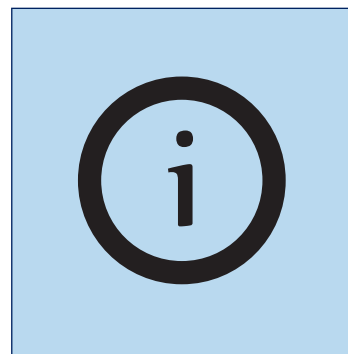

The pre-setting is carried out by specialised dealers or AAT.



**The power assist is not a braking aid. Braking the wheelchair must be done by the accompanying person.**

**That is why we always recommend drum brakes!**

## 5.6 Anti-tip supports



**WARNING** - Never use without both original anti-tip supports of the manufacturer to prevent the wheelchair from tipping backwards!



**WARNING** - Check the anti-tip supports before initial operation to ensure safety!

**Urgent recommendation by the manufacturer:** The use of anti-tip supports on the wheelchair is strongly recommended. Two anti-tip supports are compulsory on slopes of more than 8 %.

We recommend using the wheelchair manufacturer's anti-tip supports.

## 6 Starting up



**DANGER** - Operation only by a single, trained person. This person must be physically and mentally able to operate the **V-MAX mini** safely and must not suffer from cognitive impairment!



**DANGER** - Never use without both original anti-tip supports of the manufacturer to prevent the wheelchair from tipping backwards!



**DANGER** - Avoid parallel journeys on steep hillsides or rails, to prevent the wheelchair from overturning!



**DANGER** - Cross over roads, crossroads and railway crossings with increased caution!



**DANGER** - Use the brakes of the wheelchair when driving on slopes, as the **V-MAX mini** does not include a brake function! That is why we always recommend drum brakes!



**DANGER** - Do not use on escalators or travellers to avoid injuries caused by a crash or the falling out of the occupant and the occurrence of damage to property!



**WARNING** - Practise outdoors on a level surface and at low speed!  
Press the thumb throttle only lightly > intuitive speed selection!



**WARNING** - Approach slopes at low speed!



**WARNING** - Do not drive crosswise on upward/downward slopes!



**WARNING** - Only perform turns on upward/downward slopes if you are physically capable of handling the additional forces involved!



**WARNING** - Drive down slopes at the lowest speed and use the wheelchair 's brakes to avoid dangerous situations! We recommend drum brakes!



**WARNING** - Never use the battery empty or defective, as failure of the battery on upward/downward slopes will cause the device incl. wheelchair to freewheel and suddenly require much more force for handling.



**WARNING** - Do not drive up stairs or steps to prevent the wheelchair from overturning!



**WARNING** - Avoid driving in heavy rain, ice, snow and on unsurfaced ground (sand, mud, loose crushed rock) to prevent slipping!



**WARNING** - During breaks, when using public transport (buses, trams, etc.) and when changing seats, switch off the **V-MAX mini** and apply the parking brakes of the wheelchair to prevent it from rolling away.



**WARNING** - When driving on public roads, observe the road traffic regulations!



**WARNING** - Always operate the wheelchair with both hands to be able to react appropriately to dangerous situations!



**WARNING** - In the event of blocked drive elements or a change of the driving behaviour, **V-MAX mini** immediately and do not use it. Contact authorised specialist dealers or the manufacturer!





**WARNING** - Observe the maximum total permissible weight. (Refer to chapter "Technical data")!



**CAUTION** - Always overcome kerbs/obstacles backwards (refer to chapter "Overcoming obstacles").



**CAUTION** - Maintain sufficient distance to the edge of the kerb to avoid damage!



**CAUTION** - When using seat supports (cushions, etc.), ensure that the occupant is securely seated to prevent the occupant from falling out or slipping!



**NOTE** - Never pull/lift by the operating unit of the **V-MAX mini** as it has not been designed for this purpose. Use the pushing handles of the wheelchair.



**NOTE** - Do not drive backwards against walls with the anti-tip supports attached so as not to damage the anti-tip supports. We recommend using the wheelchair manufacturer's anti-tip supports.



**NOTE** - Do not pull the power cable during use!



**NOTE** - Before first start-up, the battery pack must be fully charged!



**NOTE** - The **V-MAX MINI** does not have a reverse gear. The wheelchair must be turned manually.



**NOTE** - Perform a visual inspection prior to each start-up! If parts are visibly defective or missing, contact the authorised specialist shop or the manufacturer!



**NOTE** - In the event of longer breaks, the automatic switch-off switches off the **V-MAX MINI** after approx. 15 min. To become ready to drive again, switch off the battery and switch it on again after approx. 1-3 seconds.

## 6.1 Switching on the device



**NOTE** - DO NOT operate the thumb throttle while switching on - Starting protection!



**NOTE** - The battery must be locked in place using the key for the battery locking device!



**NOTE** - The release switch must be turned completely to the right (closed point), otherwise the drive will not receive a travel signal!



Please, switch on the **V-MAX mini** only after the occupant has taken his seat.



If necessary, turn the release switch completely to the right. If not yet done.

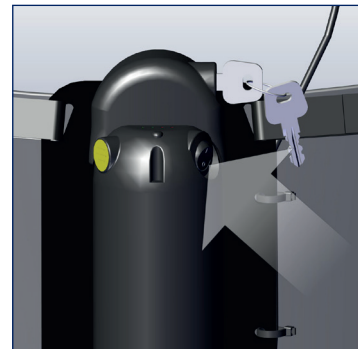

Switch on the V-MAX mini at the battery.

## 6.2 Riding with the v-MAX mini

### Battery indicator

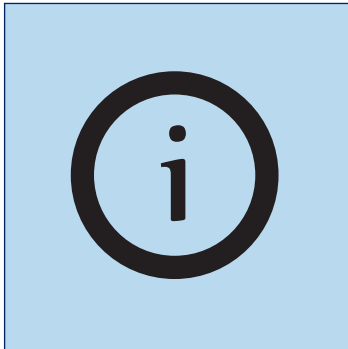

After switching on, the battery indicator updates itself and shows the actual charge level.

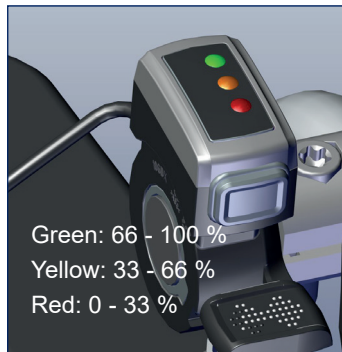

The charge level is displayed on the operating unit in 33 % increments.

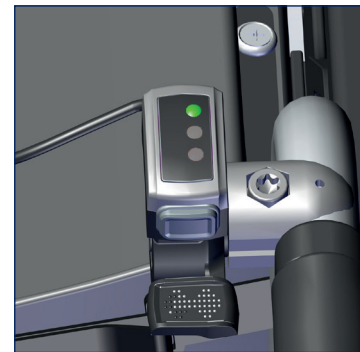

**Green = battery full (66 - 100 %)**



**Orange = battery low (33 - 66 %)**



**Red = battery empty (0 - 33 %)**  
» Charge battery!

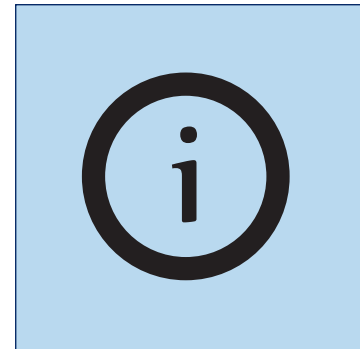

The charge level can also be read off from the battery.

### **Manufacturer's recommendation:**

Primarily use the battery indicator on the operating unit. Only read off the charge level on the battery if necessary.

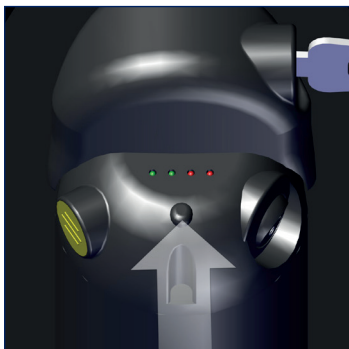

Press the button below the battery indicator LEDs.

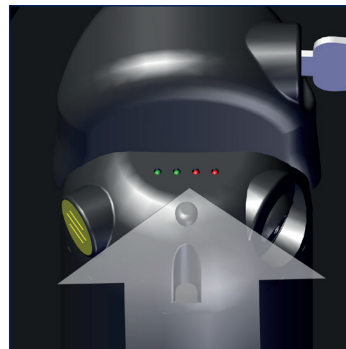

The charge level is indicated on the battery.

## Driving with the thumb throttle

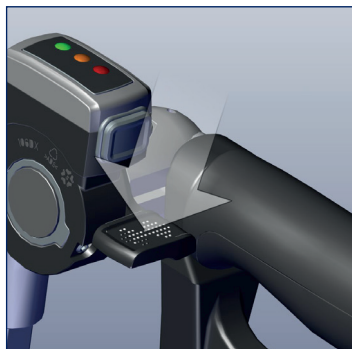

Press the thumb throttle downwards slightly.  
» The **V-MAX mini** travels forward.

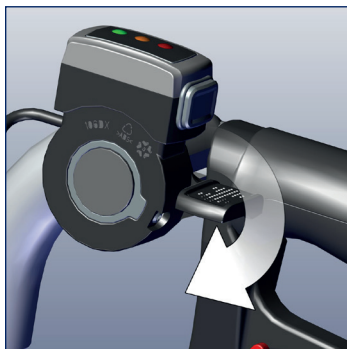

The speed increases with increasing pressure on the thumb throttle.

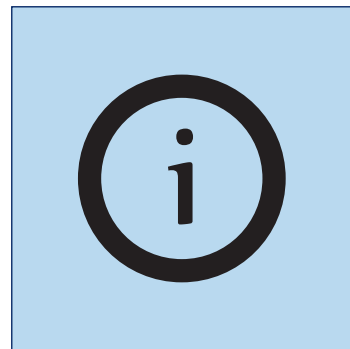

The **V-MAX mini** does not have a reverse gear. The wheelchair must be turned manually.

If the wheelchair is pulled backwards at a slower speed than 1 km/h, the thumb throttle has its full function (drives when the thumb throttle is pressed).

If the wheelchair is pulled backwards faster than 1 km/h, the thumb throttle has no function (no drive).



The power assist is not a braking aid. Braking the wheelchair must be done by the accompanying person.

That is why we always recommend drum brakes!

## Safety and information functions

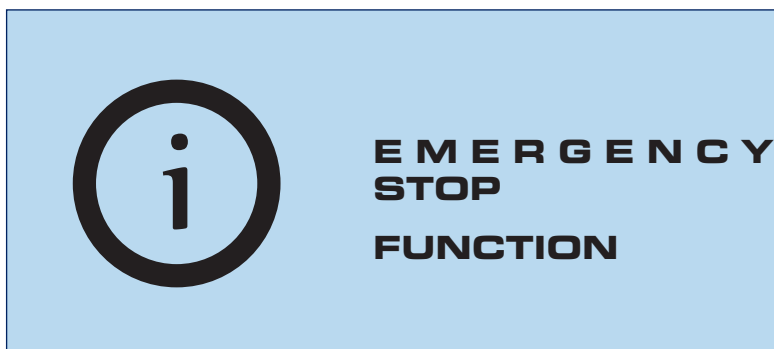



When releasing the thumb throttle, the **V-MAX mini** rolls out. Use the drum brakes of the wheelchair for braking!

In dangerous situations, the **V-MAX mini** can be switched off using the ON/OFF switch on the battery. The device is immediately deactivated.



The **status indicator informs about the current operating status** (refer to chapter "Status information" for any fault conditions and troubleshooting).

## 6.3 Overcoming obstacles / folding up

-  NOTE - Never pull/lift by the operating unit of the **V-MAX mini** as it has not been designed for this purpose. Use the pushing handles of the wheelchair.
-  NOTE - Observe the wheelchair manufacturer's information on the maximum obstacle height in the user manual without fail!
-  NOTE - Be mindful of the anti-tip supports if you need to climb edges or obstacles as they can otherwise be damaged.

To overcome high obstacles, fold up the **V-MAX mini**.

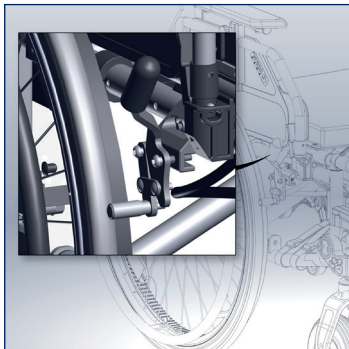

Activate the parking brakes of the wheelchair.

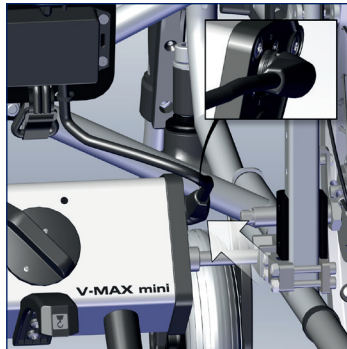

If necessary, disconnect the power cable from the socket of the drive unit.



The release switch remains turned to the right.  
» The guide shafts are located in the bracket.

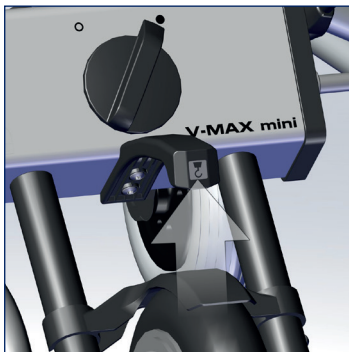

Lift the **V-MAX mini** by the handle.  
» Observe the symbol for attaching the double hook.



Fold up the **V-MAX mini**.

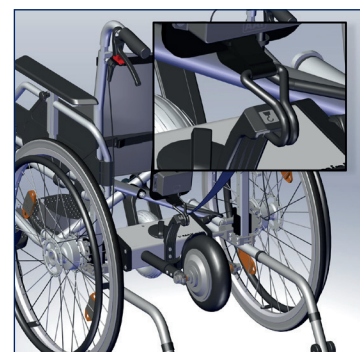

Attach the handle to the double hook.  
» Observe the symbol for attaching the double hook.

To fold down the **V-MAX mini** follow the steps in this chapter in reverse order.

## 6.4 Deactivating the drive

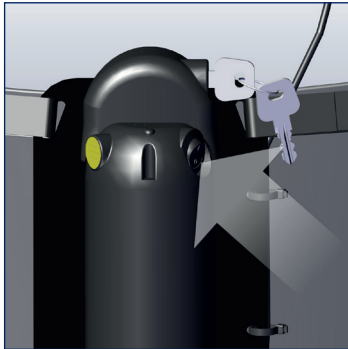

### Switch off the V-MAX mini.

Press the ON/OFF switch.

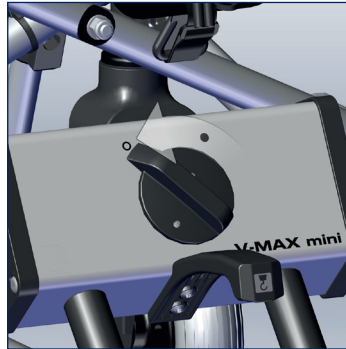

Turn the release switch completely to the left.

» The guide shafts retract.

### Note by the manufacturer:

If the **V-MAX mini** is not used for a longer period of time, the battery could discharge itself. Therefore, please ensure that the drive is deactivated correctly.

## 6.5 Immobiliser / protection against unauthorised use

To protect the **V-MAX mini** from unauthorised use, observe the following steps. They prevent unwanted use of the **V-MAX mini**.

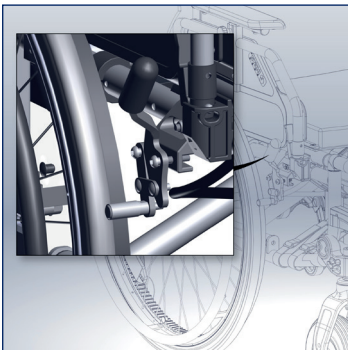

Activate the parking brakes of the wheelchair.

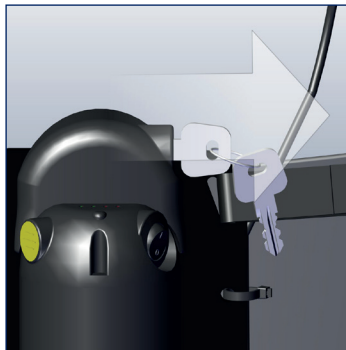

Turn the key 180°  
» The battery is de-locked.  
Then pull off the key.

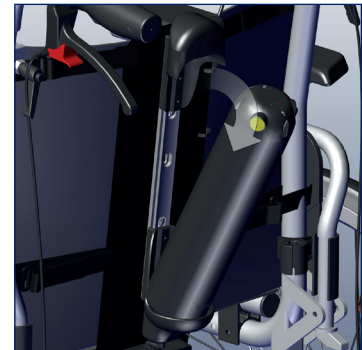

Remove the battery and take it with you.



## 7 Removal

### Taking out the battery

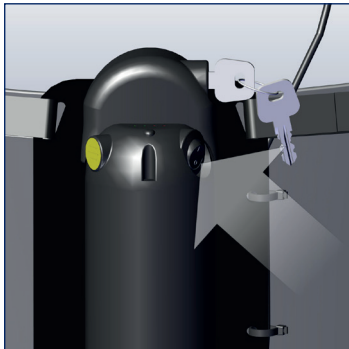

If not done already, **switch off the V-MAX mini**. Press the ON/OFF switch.

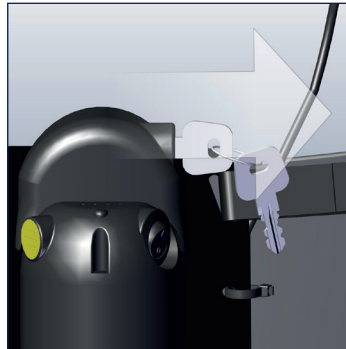

Turn the key 180°  
» The battery is de-locked.  
Then pull off the key.

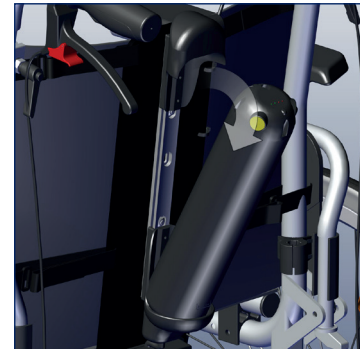

Pull off the battery.

### Removing the anti-tip supports (optional)

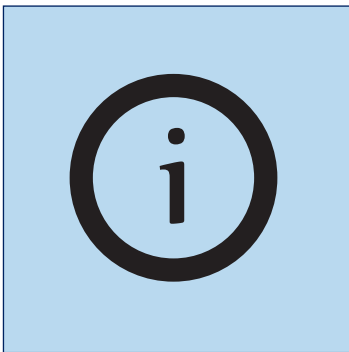

If necessary, remove the anti-tip supports according to the wheelchair manufacturer's instructions.

### Removing the operating unit / thumb throttle

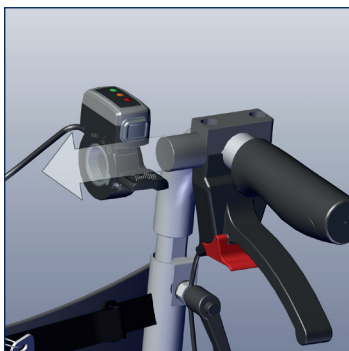

If necessary, remove the operating unit / thumb throttle from the round tube.

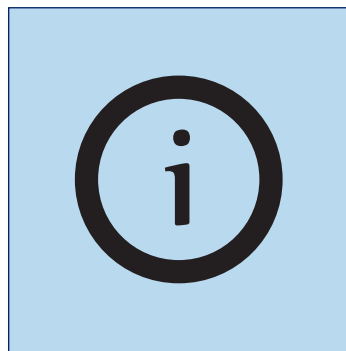

**Manufacturer's recommendation:**  
Leave the operating unit permanently fitted.

## Removing the battery holder



The battery holder is equipped with four Velcro tapes.



If necessary, pull the protruding Velcro tape out of the retaining clip. Release the Velcro tape from the upper and lower wheelchair frame.



Repeat on the other side.

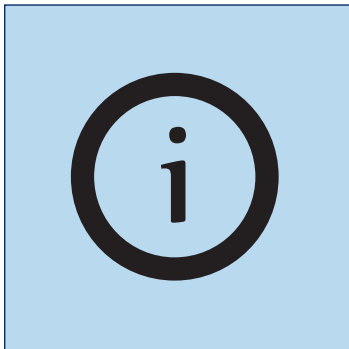

### **Manufacturer's recommendation:**

Only remove the battery holder if necessary. The folding mechanism of the wheelchair can be used without restriction even with the battery holder fitted.



## 8 Transportation



WARNING - Do not use the **V-MAX mini** with wheelchair as a seat in a vehicle!



WARNING - Secure according to valid statutory provisions during transport in vehicles/aeroplanes!



CAUTION - Switch off during transport!



CAUTION - Observe the vehicle's weight specifications!



NOTE - Store in a frost-free environment at least one hour prior to start-up to avoid malfunctions!



### Information by the manufacturer:

Lithium-ion batteries are considered dangerous goods, but are approved for air freight transport according to DOT + IATA. As the lithium-ion battery of the V-MAX mini is less than 300 Wh, it can be carried in hand luggage.

Nevertheless, contact the airline in advance before taking a flight to clarify the registration of the lithium-ion battery. If you need transport certificates for the airline, you will find them on our homepage at: <https://www.aat-online.de/safetystatement>

Deactivate the **V-MAX mini** (refer to chapter "Deactivating the drive").

Remove the **V-MAX mini** (refer to chapter "Removal").

Stow securely in the vehicle boot.

- » Hold the **V-MAX mini** by the carrying handle.
- » The battery holder does not necessarily have to be removed from the wheelchair.

## 9 Care and maintenance



WARNING - Repairs and technical safety tests are performed by the manufacturer, the AAT field staff or the authorised specialist shop!



NOTE - Perform a visual inspection prior to each start-up! If parts are visibly defective or missing, contact the authorised specialist shop or the manufacturer!



NOTE - It is recommended to perform a technical safety test every two years. The inspection plate provides information about the latest date. Tip: After a change in operator/reuse.

## 9.1 Battery and charger



**DANGER** - Before shipping lithium-ion batteries (repair, disposal, etc.), it is mandatory to inform your specialist dealer or the manufacturer, as there is increased danger! Special shipping conditions may require specific packaging, among other things! Your specialised dealer will receive approved transport containers on request - shipping may only be carried out via the specialised dealer!



**WARNING** - Never short-circuit or connect the poles of the battery to avoid electric shocks!



**CAUTION** - During the charging procedure, ensure that cables are laid safely to avoid tripping over them!



**CAUTION** - Do not attempt to repair or bypass defective fuses to avoid electric shocks!



**CAUTION** - Protect against moisture to avoid electric shocks!



**NOTE** - Never carry the charger by the charging cable/charging line.



**NOTE** - Charge the battery after each use! Exhaustive discharge results in a loss in capacity and shortens the service life.



**NOTE** - Protect the charger and the motor vehicle voltage converter against oils, greases, aggressive cleaning agents, thinning agents or damage.



**NOTE** - Observe the user manual for the charger/voltage converter.



**NOTE** - Store the battery in a frost-free environment at least one hour prior to start-up to avoid malfunctions.



**NOTE** - Do not charge the battery near heat-sensitive or flammable materials.

**Recommendation:** Remove the battery from the charger for long-term storage (or non-use). Carry out regular trickle charges at intervals of 1 month, then remove the battery from the charger again.



### Information by the manufacturer:

The battery is maintenance-free and rechargeable. New batteries only reach their full capacity after several charging cycles. During the charging process, the **V-MAX mini** cannot be operated.

## Charging the battery on the wheelchair

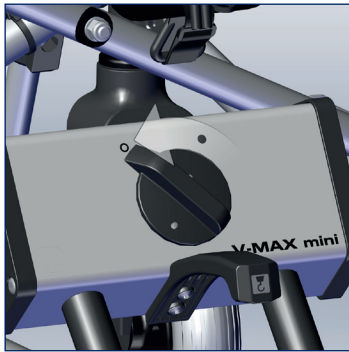

Deactivate the **V-MAX mini** (refer to chapter "Deactivating the drive").

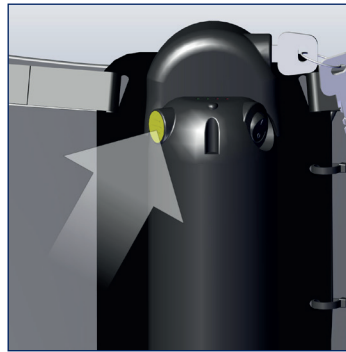

Open the yellow rubber cover over the charging socket.

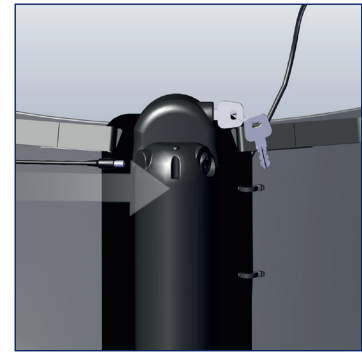

Connect the charger.  
» The battery can remain in the battery holder while being charged.



LED green = battery full  
approx. 4 hours

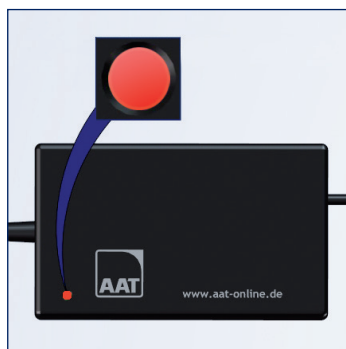

LED is red = battery is being  
charged

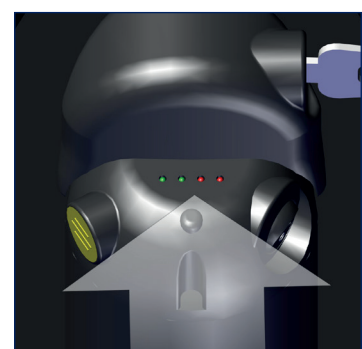

Check the capacity on the  
battery (refer to chapter  
"Battery indicator").

## Charging the battery outside the wheelchair

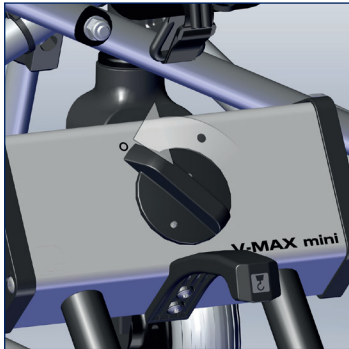

Deactivate the **V-MAX mini** (refer to chapter "Deactivating the drive").

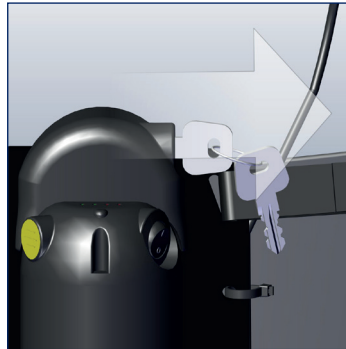

Turn the key 180°  
» The battery is de-locked.  
Then pull off the key.

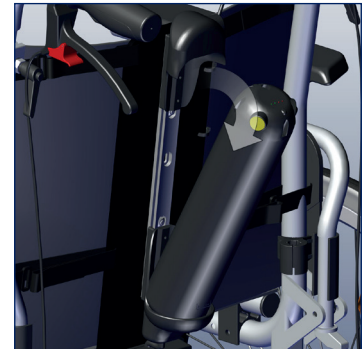

Pull off the battery.

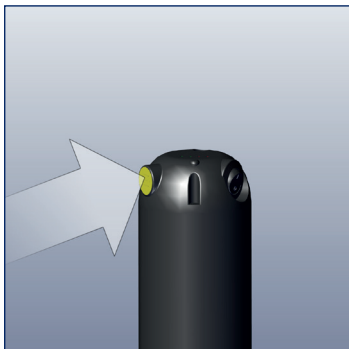

Open the yellow rubber cover over the charging socket.

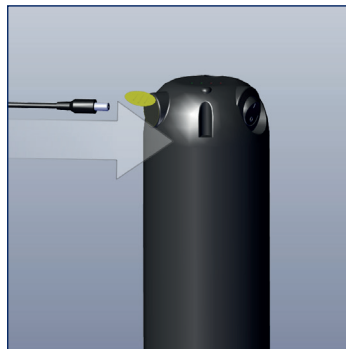

Connect the charger.

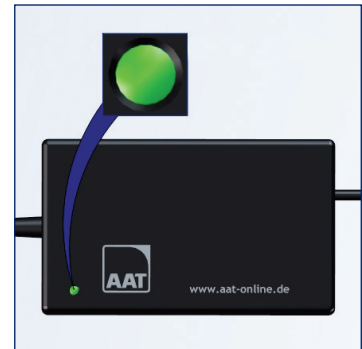

LED green = battery full  
approx. 4 hours

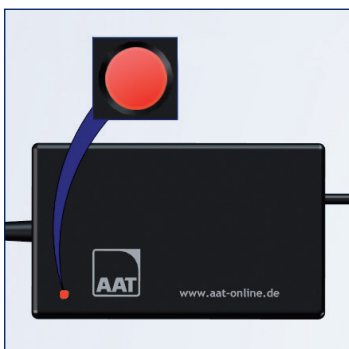

LED is red = battery is being charged

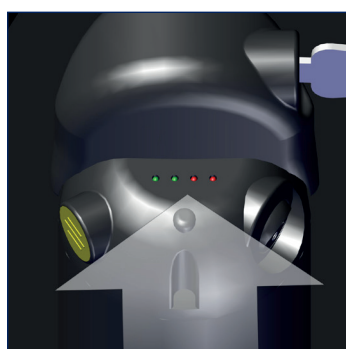

Check the capacity on the battery (refer to chapter "Battery indicator").

## Charging batteries in car

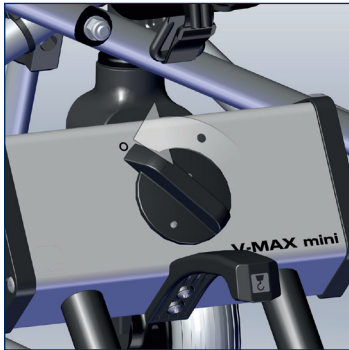

Deactivate the **V-MAX mini** (refer to chapter "Deactivating the drive").

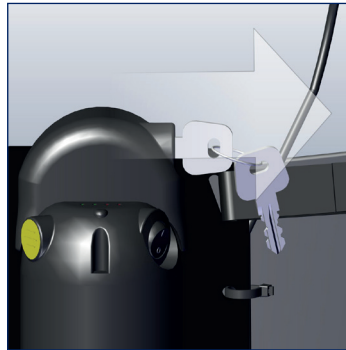

Turn the key 180°  
» The battery is de-locked.  
Then pull off the key.



Pull off the battery.

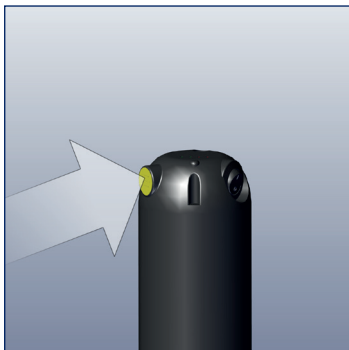

Open the yellow rubber cover over the charging socket.

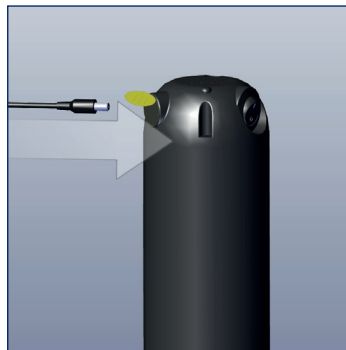

Connect the charger.

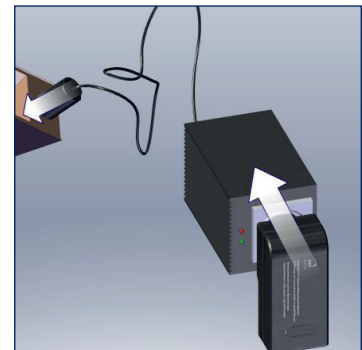

Connect voltage converter and charger.



LED green = battery full  
approx. 4 hours

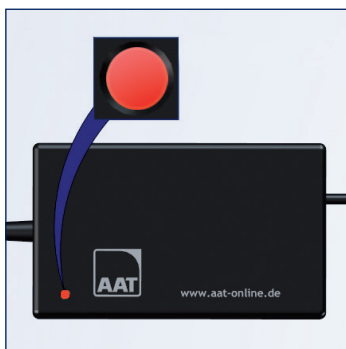

LED is red = battery is being charged

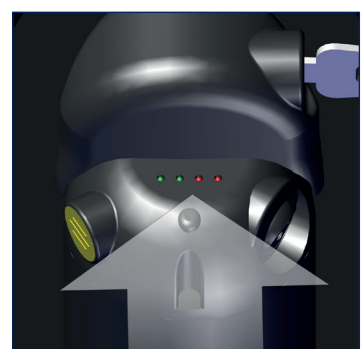

Check the capacity on the battery (refer to chapter "Battery indicator").

## Information on the charger

 Note - Observe the manufacturer's information in the charger's user manual!



### Charger **V-MAX mini**

- » Lithium-ion battery
- » Battery capacity  
6.0 - 6.4 Ah.

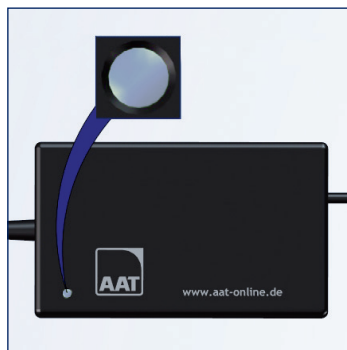

### Possible error

LED does not light up.  
Contact the manufacturer!

## 9.2 Cleaning and disinfection



WARNING - No moisture must be allowed to enter the interior of the device!  
This may result in electric shocks! Use only damp cloths for cleaning the device's surface!  
Never use wet cloths!



WARNING - Test all safety-relevant functions after cleaning!



WARNING - Do not smoke during cleaning!



NOTE - Keep the **V-MAX mini** away from sources of ignition!



NOTE - In case of soiling/deposits, clean the drive unit, operating unit and battery holder!



NOTE - Clean the wheelchair according to the manufacturer's information!



NOTE - Do not use a high-pressure cleaner!



NOTE - Do not use abrasive or aggressive agents (if necessary, test on an inconspicuous area first)!



NOTE - Do not use substances containing alcohol!



NOTE - Do not use acidic substances such as orange cleaner!

Wipe the surfaces of the **V-MAX mini** with mild household cleaning agents.  
» Observe the manufacturer's information.

If you want to disinfect the **V-MAX mini**, carry out a wipe disinfection.

Use household disinfectants.  
» Observe the manufacturer's information.

### Possible disinfectants:

- Ecolab Oxy Wipe disinfectant wipes
- B15 disinfectant wipes orochemie
- Schülke mikrozyd sensitive wipes
- Sagrotan disinfection cleaner



## 9.3 Disposal



DANGER - Before shipping lithium-ion batteries (repair, disposal, etc.), it is mandatory to inform your specialist dealer or the manufacturer, as there is increased danger! Special shipping conditions may require specific packaging, among other things! Your specialised dealer will receive approved transport containers on request - shipping may only be carried out via the specialised dealer! (The regulation only applies to the lithium-Ion battery)

Your **V-MAX mini** and its batteries are durable products. After expiry of the natural service life, you can return these components to AAT Alber Antriebstechnik GmbH or their specialist dealers for disposal.

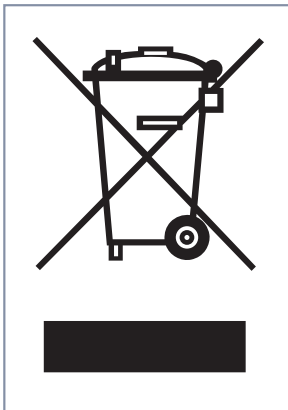

On this product you will find the symbol of the "crossed out dustbin" according to the WEEE Directive. This marking indicates that these products must be brought to a regional recycling facility when they have reached the end of their useful life.

Please check the applicable legislation in your country for the disposal of this product as the implementation of the WEEE Directive differs in the respective countries and/or, does not apply outside of Europe.

Alternatively, you can also return these products to AAT or the competent specialized dealers, where they are collected for correct disposal.

## 9.4 Long-term storage

If the **V-MAX mini** is not used for an extended period of time (e.g. over several months), observe the following information:

- Observe the wheelchair manufacturer's information if the wheelchair is to be stored!
- No moisture shall reach the inner parts of the device.
- Store in dry rooms and avoid excessive air humidity. Cover with film, if necessary!
- Protect against permanent exposure to sunlight!
- Unauthorised persons, especially children, should not have unsupervised access to the storage location of the **V-MAX mini**!
- Remove the battery before placing in storage!
- When storing the battery, it is mandatory to observe the safety instructions in the chapter "Battery and charger"!

When the **V-MAX mini** is to be put in operation again, clean the wheelchair and the product (chapter "Cleaning"). Check whether a technical safety test must be performed. (Refer to chapter "Technical safety testing")

If a technical safety test is not necessary, the electrical function, anti-tip supports (optional), brackets and, if necessary, the air pressure of the castors must be checked prior to start-up!

## 9.5 Technical safety testing



NOTE - Technical safety tests may only be performed by the manufacturer, the AAT field staff or the authorised specialist shop.



NOTE - It is recommended to perform a technical safety test every two years. The inspection plate provides information about the latest date. Tip: After a change in operator/reuse.



The test badge shows when the test is to be carried out at the latest!

Improper use can lead to damage on the **V-MAX mini** which may impair the technical functionality. For this reason, a technical safety test should be carried out every 2 years. We also recommend the technical safety test before each reuse.

Training is required in order to be able to perform the technical safety testing. For more information, please visit: [www.aat-online.de](http://www.aat-online.de)

## 9.6 Reuse (change in operator)

The term reuse is used when the AAT product of patient X is to be used for another patient Y. In addition, there is a reuse when a patient receives a different wheelchair and therefore requires new add-on parts.

Please contact the manufacturer, the AAT field service or the authorised specialist shop.

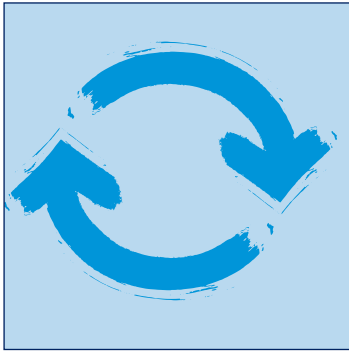

The **V-MAX mini** is suitable for reuse.

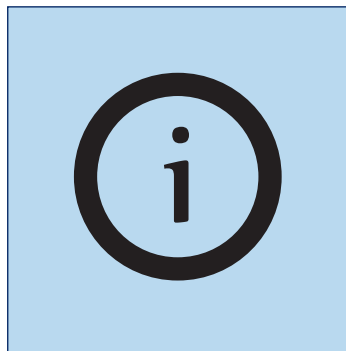

A technical safety test and cleaning/disinfection work should be performed prior to each reuse. (Refer to the chapters "Cleaning" and "Technical safety testing")

## 9.7 Corrective action/recall

If new important safety information regarding the handling of your product is available, we will inform you about this. As already stated at the beginning, you will always find the latest version of this user manual on our homepage.

Should any subsequent changes be made to the product or corrective action be taken, we will inform our authorised dealers in writing about all the affected serial numbers. If your product is affected by a recall, you will subsequently be informed about all further steps to be taken.

## 10 Status information

### 10.1 Fault conditions

The flashing pulses are continuous and separated by a clearly visible pause.



The status indicator LED is flashing.

The LED is flashing	Fault condition
1 x	Error, non-volatile memory
2 x	Undervoltage, battery
3 x	Excessive voltage, battery
4 x	Error, thumb throttle
5 x	Error Motor controller
6 x	Error Overload (excessive current)

#### Resuming driving after error code:

1. Switch off the V-MAX mini at the ON/OFF switch of the battery
2. Wait 1 - 3 seconds
3. Switch on the V-MAX mini at the ON/OFF switch of the battery
4. Continue driving, refer to chapter 6.2 Driving with the thumb throttle

### 10.2 Troubleshooting

Problem	Check and possible remedy
<b>V-MAX mini</b> cannot be switched on	Battery connected to the charger when installed? Yes: Remove the charger!
	V-MAX mini not connected to the battery via power cable? No: Plug it in!
	Is the battery empty? Yes: Charge!
	Fuse broken? Yes: Change!
	Does the problem persist? Yes: Notify the manufacturer, the AAT field service, the authorised specialist dealer.
<b>V-MAX mini</b> does not drive	Is the V-MAX mini switched on? No: Switch it on.
	Has the release switch been turned to the right? No: Turn it to the right.
	Battery not inserted correctly or empty? Yes: Insert or load!
	Thumb throttle pressed before or during switch-on? Yes: Release the thumb throttle, switch the battery off and on again!
	Drive has switched itself off after a long period of non-use? Yes: Switch the battery off and on again!
	Does the problem persist? Yes: Notify the manufacturer, the AAT field service, the authorised specialist dealer.

Unable to load the battery pack	Is the charger connected? No: Connect it correctly!
	Does the problem persist? Yes: Notify the manufacturer, the AAT field service, the authorised specialist dealer.
Fuse often defective	Yes: Notify the manufacturer, the AAT field service, the authorised specialist dealer.

## 11 Warranty and liability

### Warranty

AAT Alber Antriebstechnik GmbH assumes the guarantee for the **V-MAX mini** (except the battery) and all accessories, for a period of two years from the date of receipt, that these are free of material and processing defects.

For the **lithium-ion battery**, always assuming correct care and maintenance, AAT Alber Antriebstechnik GmbH grants a warranty of **twelve months** from the date of purchase.

The warranty on the **V-MAX mini** does not cover faults which are due to:

- damage as a result of excessive strain.
- any damage resulting from careless handling.
- violent damage.
- natural wear parts.
- improper or inadequate maintenance by the customer.
- unauthorised structural changes or improper use of the **V-MAX mini** or its accessories.
- use of the **V-MAX mini** beyond the total permissible weight.
- improper charging of the battery.





TRANSLATION OF THE ORIGINAL

# EU DECLARATION OF CONFORMITY

We hereby declare under our sole responsibility

**AAT Alber Antriebstechnik GmbH**

Ehstetter Weg 11

72458 Albstadt/Germany

SRN: DE-MF-000007581

that the power assist devices for manual wheelchairs named in the following

**As of serial number: P1204230026**

**Risk class: Class I**

(in accordance with Annex VIII, Rule 1 and 13)

Power assist **V-MAX mini P1204**

Article no. 315000

(Basis-UDI-DI) 4054959P1204MG

complies with the basic safety and performance requirements and applicable parts of the following regulations and standards.

2017/745/EU	ISO 7176-21; ISO 7176-14; EN 12184; EN ISO 21856; EN ISO 10993-1 IEC 60335-2-29; IEC 60335-1
2011/65/EU	EN IEC 63000

The products are marked with **CE** in compliance with the regulations. This declaration is only valid for the products with the article numbers indicated above. This declaration is replaced whenever there is a significant change to the product, product family, standards and laws.

01/06/2023, Albstadt

Date, place

Daniel Mohr, PRRC (MDR 2017/745 Art.15)



**Your contact persons:**

AAT Service-Center · Ehestetter Weg 11 · 72458 Albstadt  
Tel.: +49.(0) 74 31.12 95-550 · E-Mail: [service@aat-online.de](mailto:service@aat-online.de)

**Serial number:**



[www.aat-online.de](http://www.aat-online.de)



AAT Alber Antriebstechnik GmbH  
Postfach 10 05 60  
72426 Albstadt · Germany  
Phone: +49.(0) 74 31.12 95-0  
Fax: +49.(0) 74 31.12 95-35  
[info@aat-online.de](mailto:info@aat-online.de) · [www.aat-online.de](http://www.aat-online.de)